

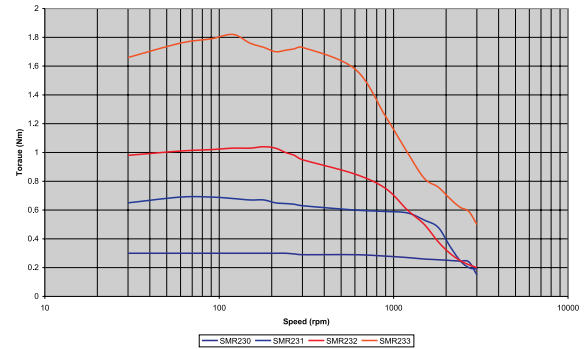

G Series 23 Frame Stepper Motors with Encoder

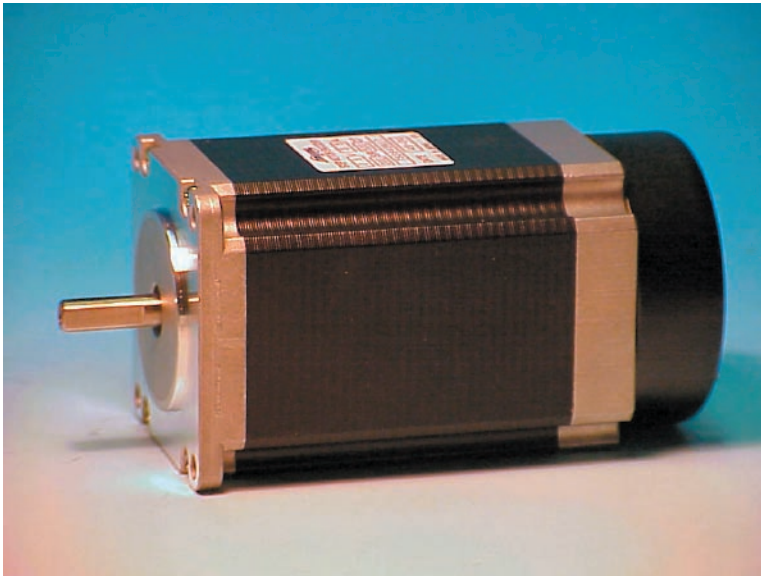

SmartDrive's NEW G Series 23 frame stepper motors bring you the latest high-performance hybrid stepper motor technology at an economical price. High-Torque Rare-Earth Magnet designs offer unprecedented torque to inertia ratios to deliver the best performance for your application. Factory fitted with a 5V differential 500 pulse per revolution encoder.

| | SMR230-042-G-FE500 | SMR231-042-G-FE500 | SMR232-042-G-FE500 | SMR233-050-G-FE500 |
|------------------------------------|--------------------|--------------------|--------------------|--------------------|
| Unipolar Current (A) | 3.0 | 3.0 | 3.0 | 3.5 |
| Drive | DM55/9 | DM55/9 | DM55/9 | DM55/9 |
| Phase Resistance (Ω) | 0.63 | 0.75 | 1.0 | 0.82 |
| Inductance (mH) | 0.6 | 1.2 | 1.6 | 1.4 |
| Holding Torque (Nm) | 0.343 | 0.88 | 1.34 | 1.4 |
| Rotor Inertia (g•cm ²) | 120 | 260 | 430 | 520 |
| Weight (Kg) | 0.45 | 0.7 | 1.0 | 1.3 |
| Body Length 'L' (mm) | 39 | 54 | 76 | 84 |
| Leads | 8 | 8 | 8 | 8 |
| UK Stock | × | ✓ | × | ✓ |

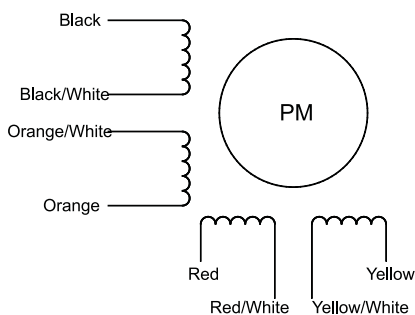
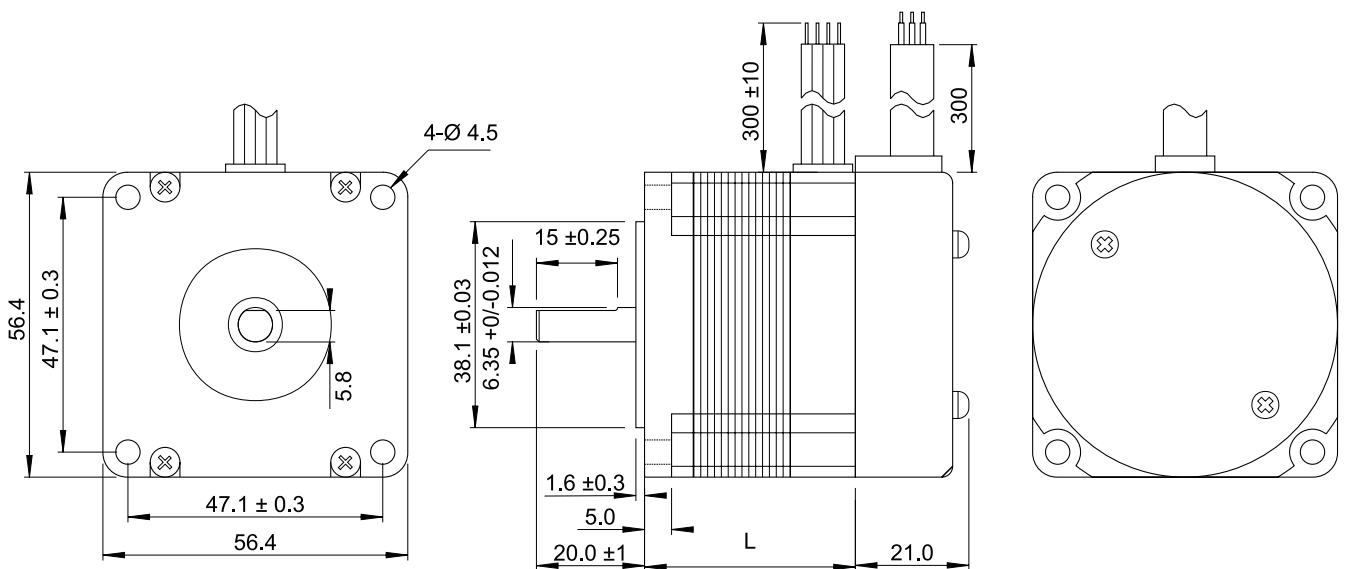

| | 1A | Link | 1B | 2A | Link | 2B |
|----------|----------------------|----------------------------|----------------------|--------------------|--------------------------|--------------------|
| Parallel | Black & Orange/White | N/A | Black/White & Orange | Red & Yellow/White | N/A | Red/White & Yellow |
| Series | Black | Black/White & Orange/White | Orange | Red | Red/White & Yellow/White | Yellow |

| DC +5V | GND | A | /A | B | /B | Z | /Z |
|--------|------|-------|--------|--------|------|-------|-------|
| Red | Blue | Brown | Orange | Yellow | Gray | Green | Clear |