



**SmartDrive**

• DRIVES AND CONTROLS •



ELECTRONICS

Full Digital Servo Drive

# **CSDJ-Series**



# System Configuration Diagram

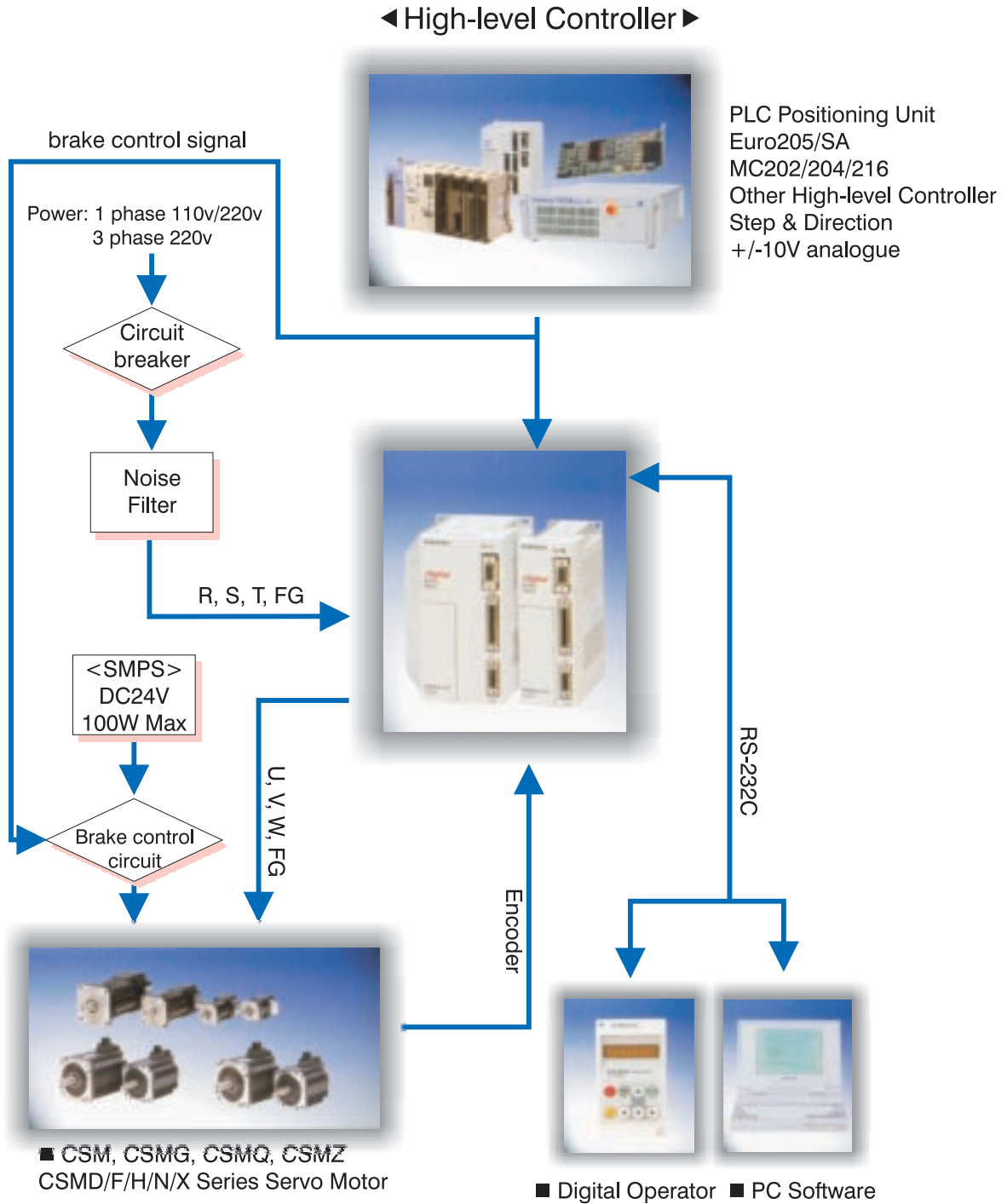

### User Friendly Operation & Configuration

Convenient digital operator control

- Easy mode change
- Easy data change
- Self test function

Windows®9x Communication Software

- Load/save parameters from/to disk
- Oscilloscope function provided
- I/O status display

Automatic measurement of load inertia ratio

- Easy selection of acceleration/deceleration time and calculation of the regenerative resistance

D/A output scale adjustment function

Restoration of factory defaults

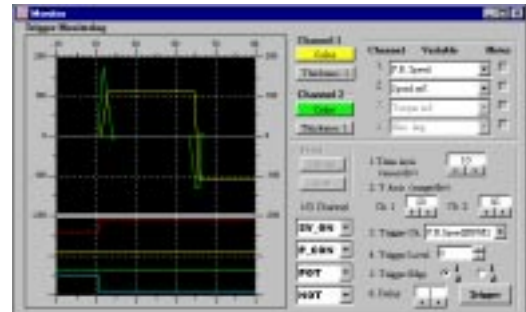

Trigger monitor mode

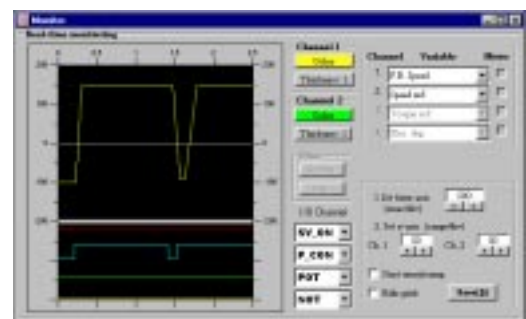

Real time monitor mode

### Full Digital & Analogue Control Available in one Unit

Position control mode

Speed control mode

Torque control mode(I, II)

Zero clamp speed control mode(auto, manual)

Multi-step speed control mode(contact input)

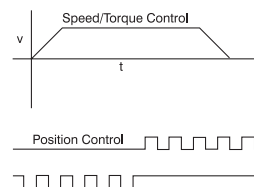

### Fast Position Decision

Position decision made within 3mS

Auto switchover function of PL/P control

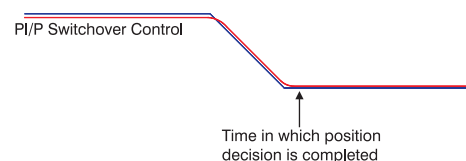
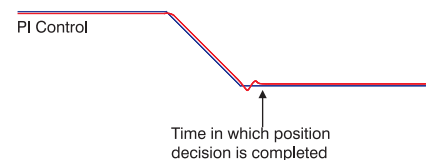

## Drive Specification - Basic

<b>Basic Specification</b>	Power <sup>*(Note 1)</sup>		Single Phase 110V +10/-15% 50/60Hz Single Phase 220V +10/-15% 50/60HZ
	Control Method		PIM Control using IPM
	Position Input <sup>*(Note 2)</sup>		2048/2500/6000 ppr nNormal/brief incremental, absolute encoder)
	Ambient Operating Conditions		0°C ~ +55°C / 90% RH (max) non condensing
	Ambient Storage Conditions		-30°C ~ +85°C / 90% RH (max) non condensing
	Vibration/Shock Resistance		0.5G / 2G
<b>I/O Specification</b>	Position	Output	Encoder A, X, Z phase output (MC3487 Line Driver)
		Demultiply ratio	N/M (N, M ≤ 8192)
	External Inputs		Servo On/Off, P Control, Forward/Reverse Run Prohibition, Forward/Reverse Current Limitation, Alarm Reset
	External Outputs		In Rotation, Brake Control, Servo Alarm/Code (3 bits) Speed Agree (Speed Control Mode), Position Agree (Position Control Mode), Z-Pulse ( Open Collector)
<b>Protection</b>	Protective Functions		Over-current, Overload, Over-voltage, Over-speed, Inverter Overheat, Low Voltage, CPU Fault, Encoder Fault, Communication Failure, Regeneration Error, etc.
	Dynamic Brake		Servo/Controller Off, Alarm Occurrence
	Regeneration <sup>*(Note 3)</sup>		For motors of less than 400W provision is made for an external auxiliary condenser and a restoration unit. For motors of 600W or more provision is made for an external restoration resistance.
<b>Monitoring</b>	D/A Output	Speed	Setting of ±1V/Set-08 [rpm] (±10V max.)
		Torque	Setting of ±1V/Set-09 [%] (±10V max.)
	External Display	LED	Power On, Servo Run, Servo Alarm (applied to all models)
	External Communication	Operator	Command values, error values, feedback values, offset values, and load inertia ratio of speed/torque/position/electric angle/mechanical angle.
		PC-Software	All Operator functions

Note 1 24VDC required for opto-isolated I/O

Note 2 Refer to motor information for encoders available

Note 3 Take care not to exceed the maximum allowable inertia for each motor

<b>Speed Control</b>	Speed Input	Speed Control Range		1 : 3000
		Speed Variation	due to Load Variation	0 ~ 100% Load : 0.01% or less
			due to Voltage Variation	+10/-15% 50/60Hz : 0.01%
			due to Temperature Variation	25±25°C : 0.01%
		Frequency Variation		400Hz ( $J_L = J_M$ )
		Accel/Decel Time-constant Setting		0 ~ 10 seconds
	Speed/Torque Input	Speed	Rated Speed Command	±6V dc (at time of manufacture)
			Input Impedance	≈50kΩ
			Circuit Time Constant	≈35μS
		Torque	Rated Torque Command	±3V dc (at time of manufacture)
Input Impedance			≈50kΩ	
Circuit Time Constant			≈35μS	
<b>Position Control</b>	Feed Forward Compensation			0 ~ 100% (Resolution 1%)
	Input Signal	Command Pulse	Type	Sign + Pulse, 90° phase difference 2-phase pulse(A-phase + B-phase), CCW pulse + CW pulse
			Pulse Type	Line Drive (+5V), Open Collector(+5V, +12V, +24V)
			Pulse Frequency	0 ~ 450kpps (line drive) 0 ~ 200kpps (open collector)
			Control Signal	Clear (Pulse Type)
Attachment Method			Base Mounted	
Others			Torque Control, Speed + Torque Control, Zero-clamp Drive, Soft-start/stop, Speed Decision, Brake Control, Jog Operation, Auto Tuning, Reverse Operation, etc.	

# Drive I/O Diagram

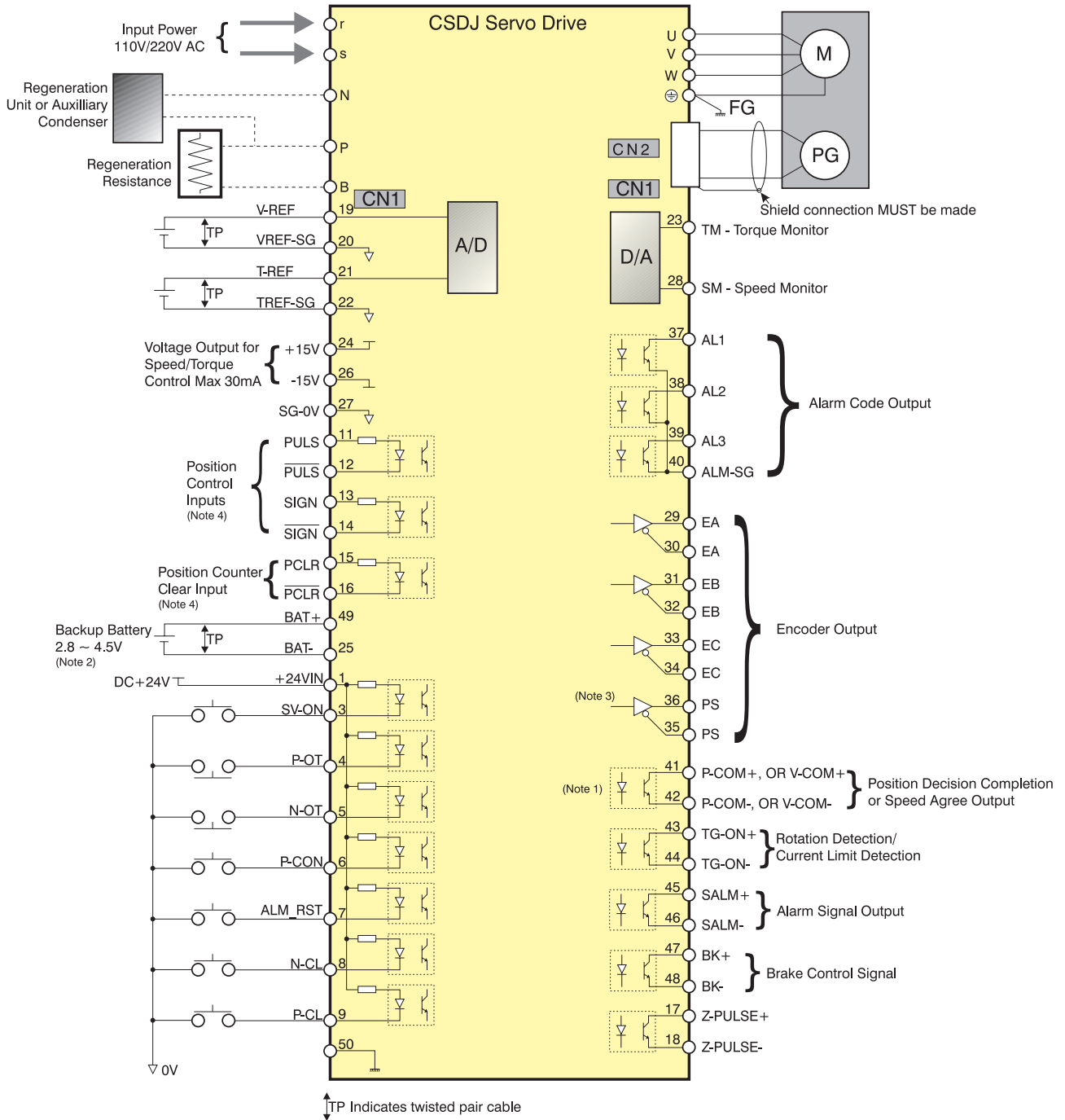

- (Note)
1. The opto-coupler capacity on the output side is 30V DC 50mA or less.
  2. Please connect when using an absolute position encoder.
  3. Valid when 12-bit absolute position encoder is used.
  4. Connect external resistors when the control voltage is greater than 5V.

PIN No.	I/O Specification		PIN No.	I/O Specification	
	Code	Function		Code	Function
1	+24EXIT	External 24V Input	26	-15V	-15V Output
2	+24EXIT		27	SG-0V	Signal Ground
3	SV-ON	Servo ON/OFF	28	SM	Speed Monitor
4	/P-OT	Forward Run Inhibit	29	EA	Encoder A Phase Output
5	/N-OT	Reverse Run Inhibit	30	/EA	
6	P-CON	Proportional Control	31	EB	Encoder B Phase Output
7	ALM-RST	Alarm Reset	32	/EB	
8	N-CL	Reverse Current Limit	33	EC	Encoder C Phase Output
9	P-CL	Forward Current Limit	34	/EC	
10		Reserved	35	/PS	Absolute Position Pulse Output
11	PULS	Position Pulse Train Input	36	PS	
12	/PULS		37	AL1	Alarm Code 1 Output
13	SIGN	Direction Control Input	38	AL2	Alarm Code 2 Output
14	/SIGN		39	AL3	Alarm Code 3 Output
15	PCLR	Clear Position Counter	40	ALM-SG	Alarm Code Signal Ground
16	/PCLR		41	P-COM+ V-COM+	Location Consistent/ Speed Consistent Output
17	Z-PULSE	Encoder Z-Pulse Output	42	P-COM- V-COM-	
18	/Z-PULSE		43	TG-ON+	Rotation Detection/ Current Limit Detection
19	V-REF	Analogue Speed Input	44	TG-ON-	
20	VREF-SG	Analogue Ground for Speed Input	45	SALM+	Servo Alarm Output
21	T-REF	Analogue Torque Input	46	SALM-	
22	TREF-SG	Analogue Ground for Torque Input	47	BK+	Brake Control Output
23	TM	Torque Monitor	48	BK-	
24	+15	+15V Output	49	BAT+	Backup Battery +ve (3.6-4.5V)
25	BAT-	Backup Battery -ve	50	FG	Frame Ground

## Dimensions & Cables

### Servo Drive

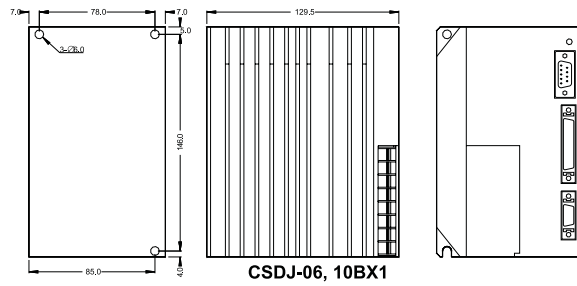
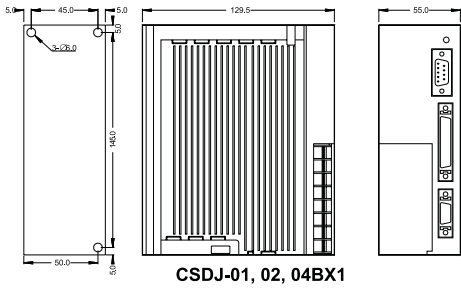

### Digital Operator

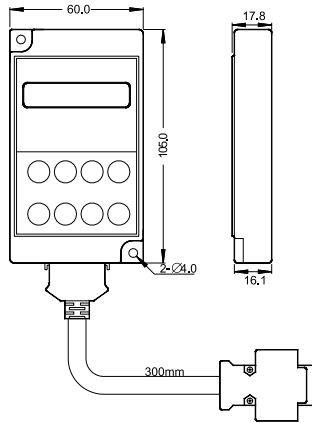

Item	Specification
Key Pad	8 Key Membrane
Display	7 Segment LED x6
Serial Interface	RS232C
Power	5V DC (Supplied by the Drive via serial cable)
External Dimensions	60 x 105 x 17.8 mm (w x H x D)
Weight	75g (Excluding cable)
Cable Length	3m
Part Number	SG-CST-SDC

### Motor Power Cable

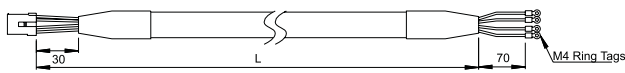

Part Number	Length ( $\pm 10\%$ )
SG-POW-SL03PO10FA	3m
SG-POW-SL05PO10FA	5m

### Encoder Cable

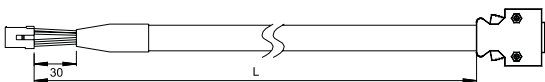

Part Number	Length ( $\pm 10\%$ )
SG-ENC-SL03ECNSFA	3m
SG-ENC-SL05ECNSFA	5m

# New Concept, New Technology! Samsung Servo System



- CSDJ Servo Drive is a full digital AC Servo Drive that adapts a 32-bit high-speed DSP.
- It can be used as one of position/speed/torque control modes, according to the system.
- With the mini, light and built-in power unit design, the optimum system configuration is available.





Distributed in the UK by

**SmartDrive Ltd**

The Old School

8 Colne Road

Earith

Cambridge

PE28 3PX

United Kingdom

Tel +44 (0)1487 843663

Fax +44 (0)1487 843661

Web <http://www.smartdrive.co.uk>

E-Mail [info@smartdrive.co.uk](mailto:info@smartdrive.co.uk)