

Singlsyn[®]

(Superior Flat Absolute Angle Sensor)

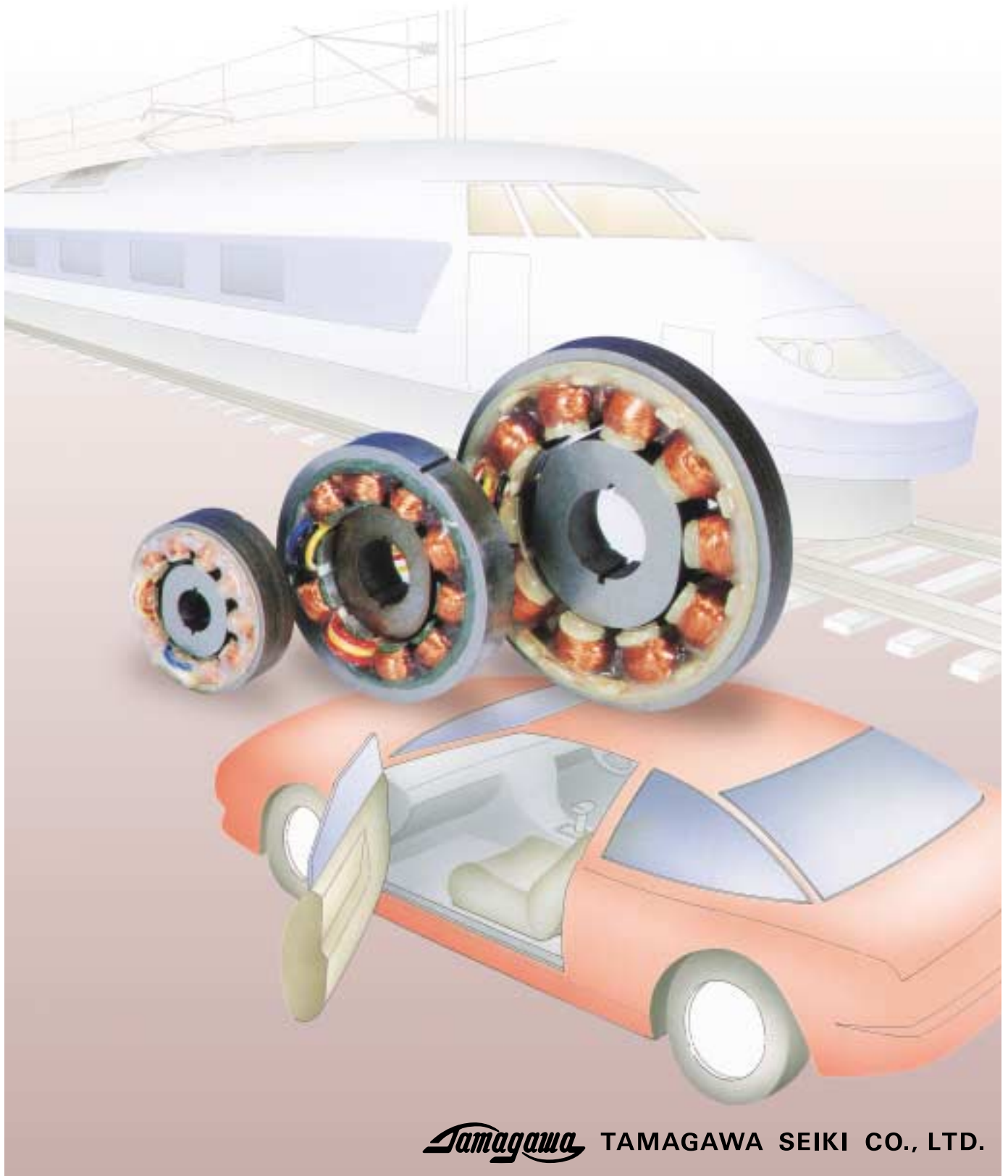

(Superior Flat Absolute Angle Sensor)

SCOPE

Singlsyn is the latest art of Absolute Angle Sensor which is developed by Tamagawa. This is a superior sensor which realizes extremely thin structure, usability in wide temperature and humidity range and in other hard environmental conditions, and high reliability. (Singlsyn is our trade mark for VR type Resolver.)

SPECIAL FEATURES

■ Extremely Thin Dimensions

Singlsyn realizes smallest mounting space because of its extremely thin thickness as a built-in structure.

■ Wide Temperature Range

-55 ~ +155°C

■ Robust for Hard Environments

- Vibration : 196 m/sec² (20G)
- Shock : 980 m/sec² (100G)
- Humidity : Up to 90% RH

■ High Rotational Speed

Up to 30,000 min⁻¹ (rpm)

■ High Reliability

Singlsyn has the similar structure to electric motors but has high reliability because of no winding coil on its motor.

■ Sensing Absolute Position and Velocity

According to connection to an R/D converter or **Smartcoder**, it is capable of converting analog output signals of **Singlsyn** to digital position (angle) signals. The position signals are transmitted as the absolute position within a range of electrical one cycle.

■ Low Cost

Especially low cost is realized by reducing the number of parts to 1/10 compared with conventional resolvers.

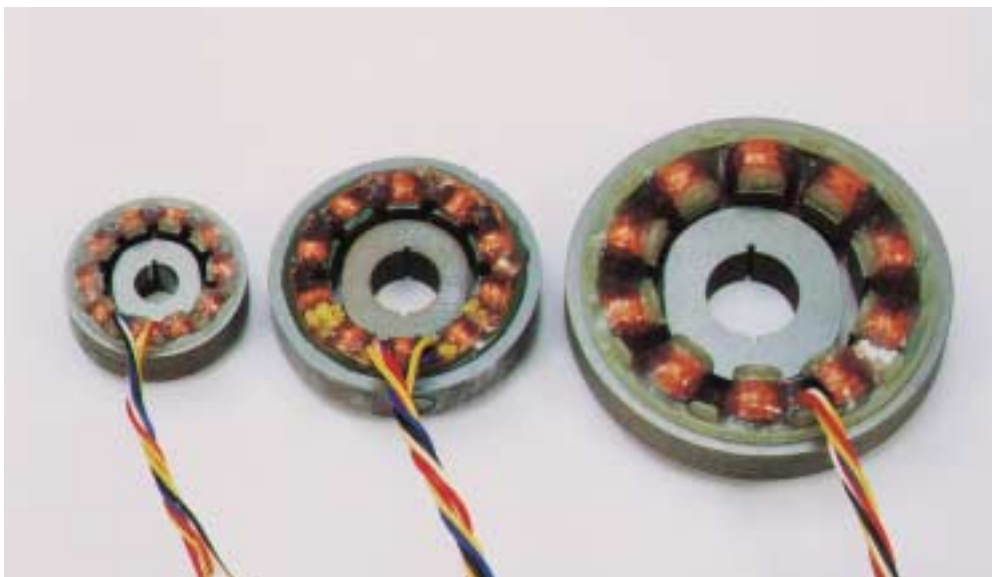

APPLICATIONS

- Detection of a rotational position of a motor and a generator on a hybrid vehicle.
- Detection of a rotational position of a motor on an electric vehicle

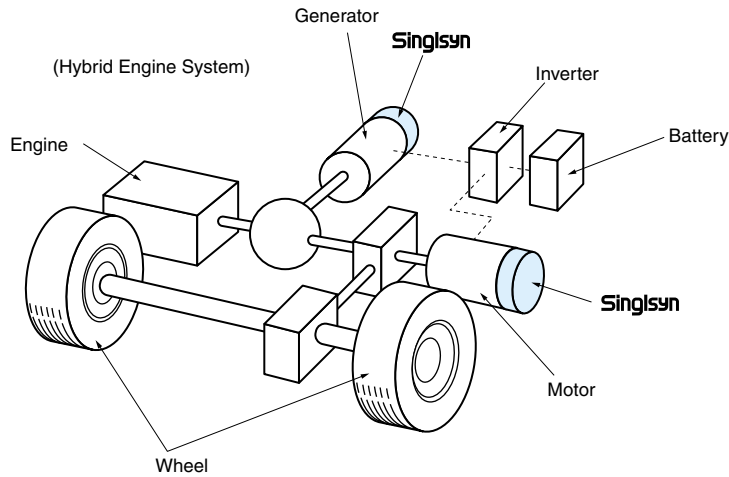

- Angle detection of a magnetic pole of a motor in an electrical power steering wheel.

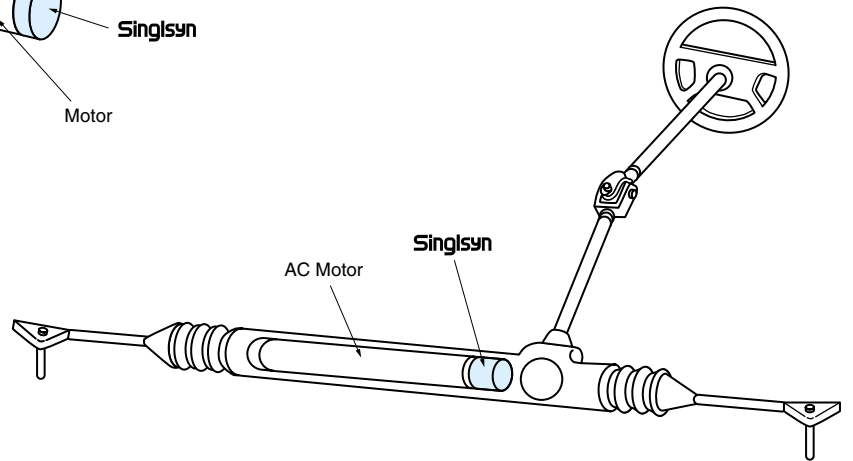

- Angle detection for controlling a fuel valve (air valve)

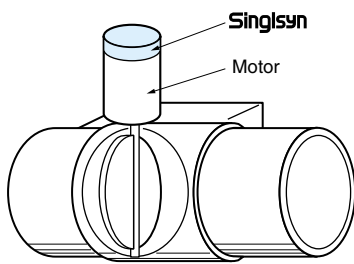

- Angle detection of a conveyer in a vacuum

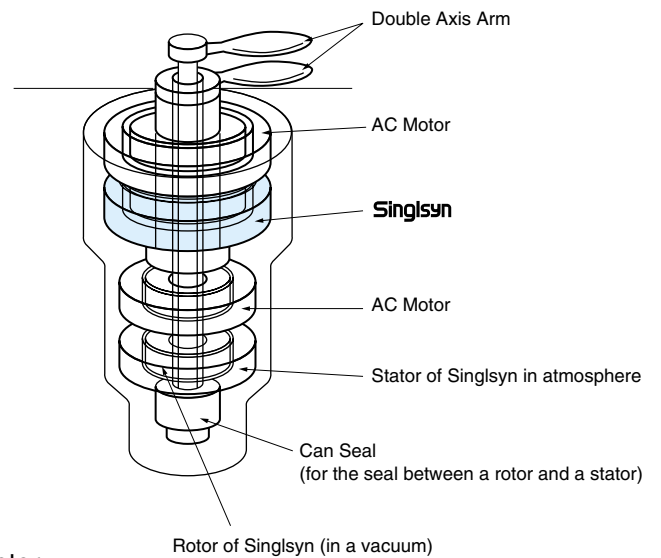

- Angle detection for control of a switched reluctance motor
- Angle detection for vector control of a high efficient induction motor
- Angle detection for rotational control of an AC motor (PM motor)

PRINCIPLE OF OPERATION

The contour of a rotor for **Singlsyn** forms specially curved air gap between its stator and the rotor, of which permeance is changed as a sinusoidal wave corresponding to an angle of the rotor shaft. One excitation winding and two output windings are placed in the stator. The two output windings detect a change of air gap between the rotor and the stator and produce output voltage with 2-phases proportional to sine and cosine of the angle of rotor. (Refer to Fig. 1 and Fig. 2)

Because the output signals of **Singlsyn** are the same as those of conventional resolvers and Smartsyns as shown in equation (2) and (3), they can be converted to digital angle data by using conventional resolver to digital (R/D) converters.

Singlsyn which produces twice angle output signals (2X type) has an elliptical shape of a rotor as shown in Fig. 3 (a). A rotor for 3X type is triangular and cross shaped for 4X type as shown in Fig. 3 (b) and 3 (c).

<Excitation Voltage>

$$E_{R1-R2} = E \sin \omega t \quad \text{————— (1)}$$

<Output Voltage>

$$E_{S1-S3} = KE \sin \omega t \cdot \cos (X \cdot \theta) \quad \text{————— (2)}$$

$$E_{S2-S4} = KE \sin \omega t \cdot \sin (X \cdot \theta) \quad \text{————— (3)}$$

where

- K : Transformation Ratio
- t : Time (s)
- θ : Shaft Angle (deg)
- f : Excitation Frequency (Hz)
- ω : $2 \pi f$
- E : Excitation Voltage (V)
- X : Multiplication Factor of Angle (X = 2, 3 or 4)

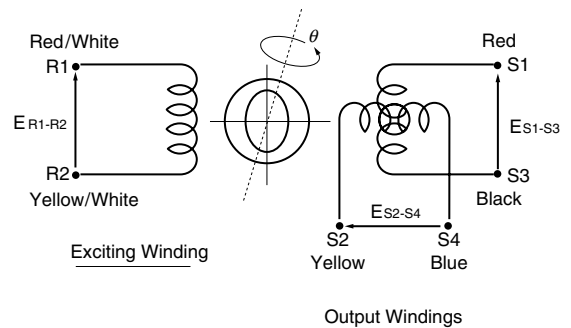

Fig. 1 Wiring Diagram

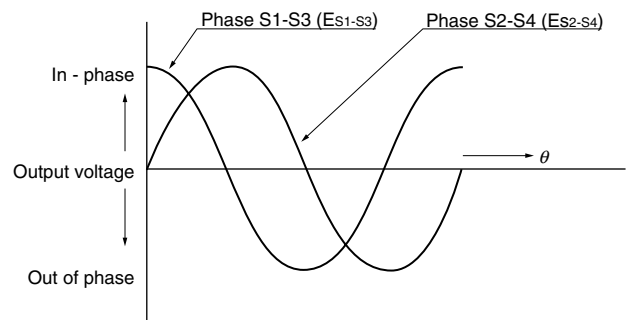

Fig. 2 Output Voltage Characteristics

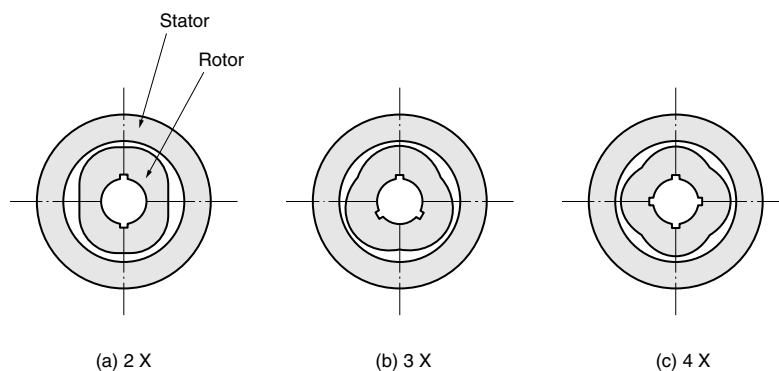

Fig. 3 Shapes of Rotors

HISTORY OF DOWN-SIZING AND PARTS-REDUCTION OF A RESOLVER

Tamagawa Seiki Co., Ltd. has been developing and manufacturing resolvers more than 40 years. The progress regarding the resolver was a history of reducing their size and cost at the same time.

Originally the military specifications of resolvers with brushes had two windings on both a rotor and a stator. Even after resolvers came through a brushless type and a built-in type, **Smartsyn** still needs four windings on a rotor, a stator and a rotary transformer (rotor and stator).

Compared with these conventional resolvers, the newly developed VR (Variable Reluctance) type resolver needs the winding on a stator only. We named this new product **Singlsyn**.

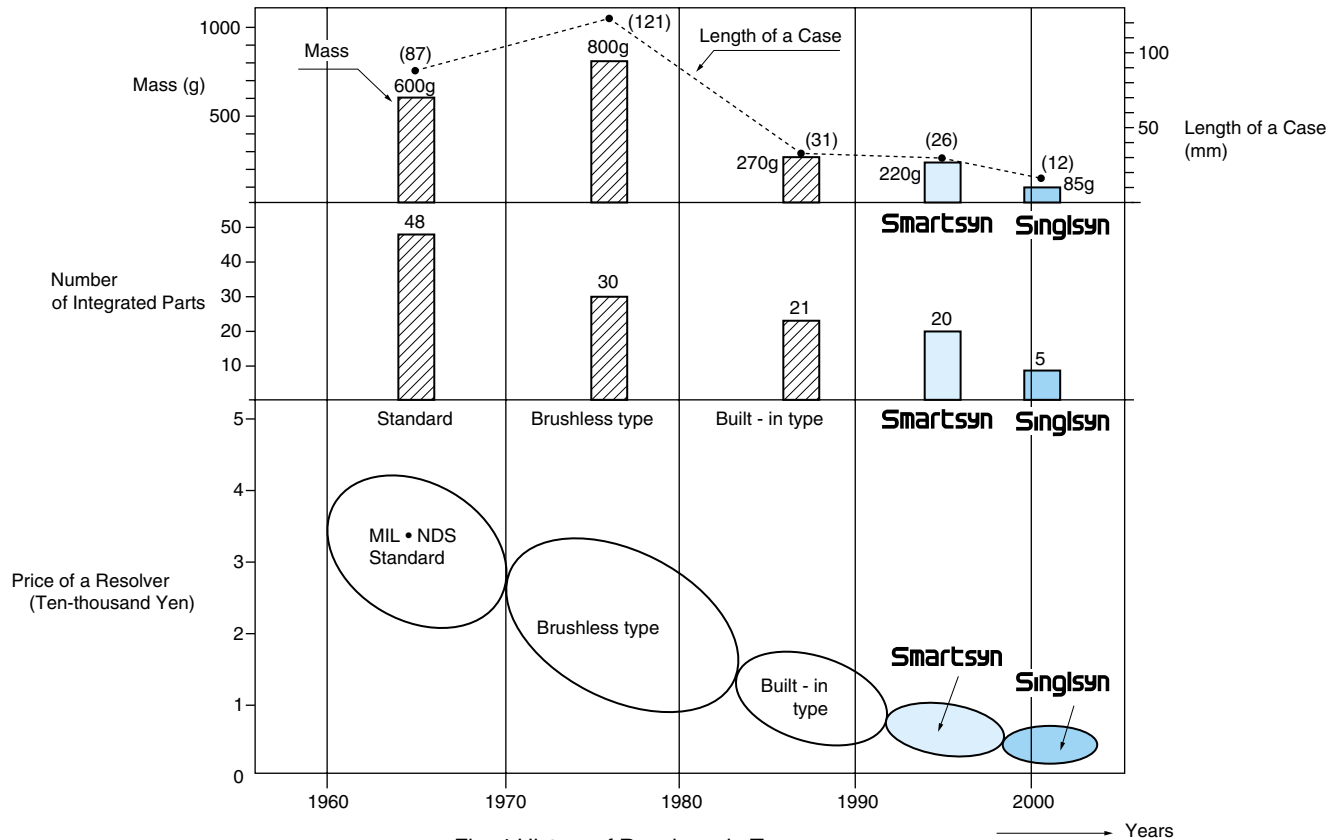

Fig. 4 History of Resolvers in Tamagawa

Structural Comparison of Smartsyn and Singlsyn

The structural differences between the conventional winding type brushless resolver (**Smartsyn**) and the newly developed **Singlsyn** are shown in Fig. 5.

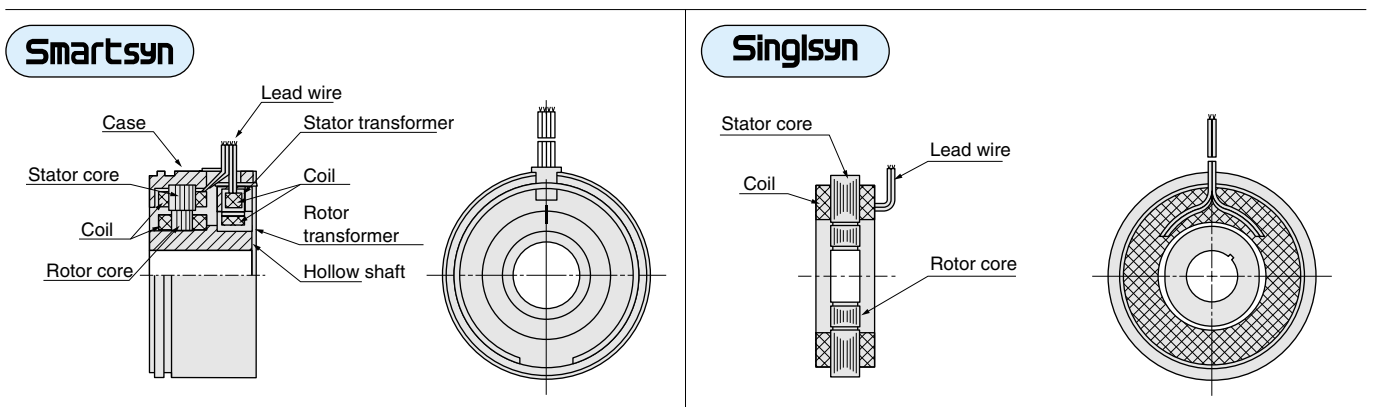

Fig. 5 Structural Comparison of **Smartsyn** and **Singlsyn**

SPECIFICATIONS

FUNCTION	2X-BRX			3X-BRX			4X-BRX		
	S10	S15	S21	S10	S15	S21	S10	S15	S21
Model Number	TS2223N12E102	TS2224N12E102	TS2225N12E102	TS2223N13E102	TS2224N13E102	TS2225N13E102	TS2223N14E102	TS2224N14E102	TS2225N14E102
Excitation Input	AC7Vrms 10kHz			AC7Vrms 10kHz			AC7Vrms 10kHz		
Primary Side	R1 - R2			R1 - R2			R1 - R2		
Transformation Ratio	0.286 ± 10%			0.286 ± 10%			0.286 ± 10%		
Electrical Error	±60°Max.			±45°Max.			±30°Max.		
Input Impedance: Zro	120 Ω ± 20%			120 Ω ± 20%			120 Ω ± 20%		
Output Impedance: Zss	350 Ω Nom.	250 Ω Nom.	270 Ω Nom.	330 Ω Nom.	260 Ω Nom.	290 Ω Nom.	430 Ω Nom.	340 Ω Nom.	335 Ω Nom.
Phase Shift	+ 15° Typ.	+ 10° Typ.	0° Typ.	+ 25° Typ.	+ 5° Typ.	0° Typ.	+10° Typ.	0° Typ.	-10° Typ.
Mass	0.023kg	0.050kg	0.090kg	0.023kg	0.050kg	0.090kg	0.023kg	0.050kg	0.090kg

OUTLINE DIMENSIONS

S10// TS2223N10 Series

2X : TS2223N12E102
 3X : TS2223N13E102
 4X : TS2223N14E102

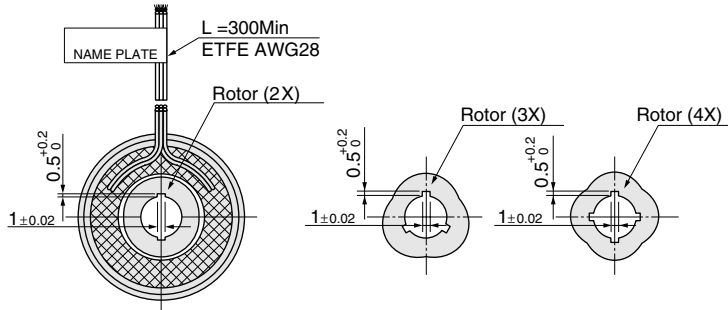
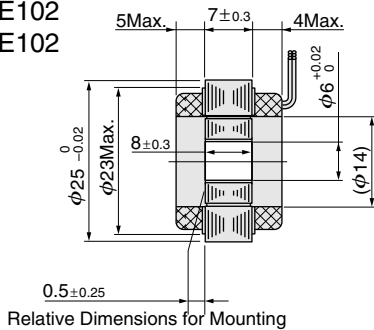

S15// TS2224N10 Series

2X : TS2224N12E102
 3X : TS2224N13E102
 4X : TS2224N14E102

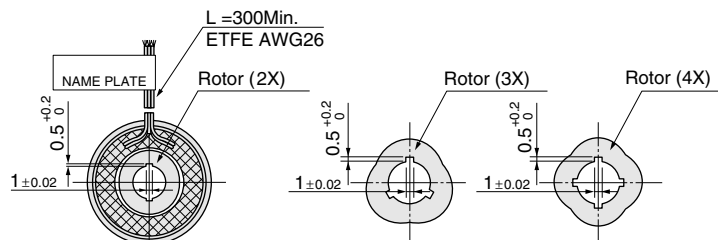
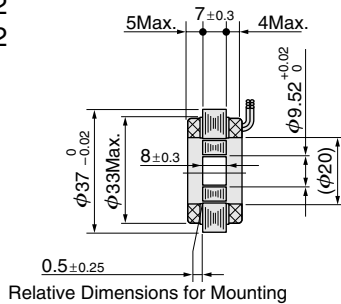

S21// TS2225N10 Series

2X : TS2225N12E102
 3X : TS2225N13E102
 4X : TS2225N14E102

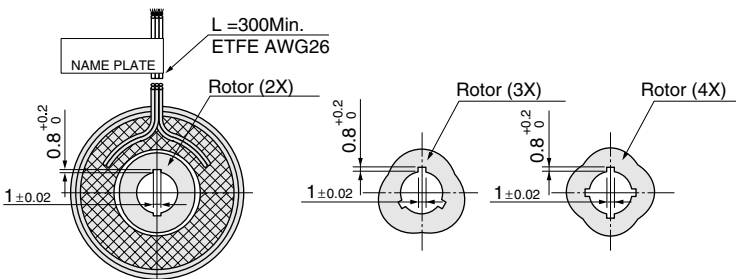
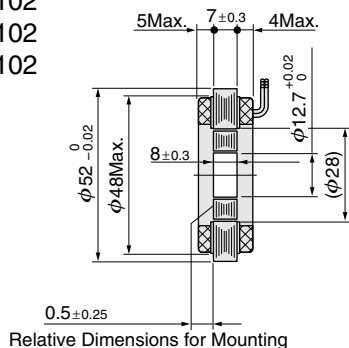

All dimensions are described in milli-meter.

MOUNTING METHOD AND ACCURACY

● Mounting Method (Built-in type)

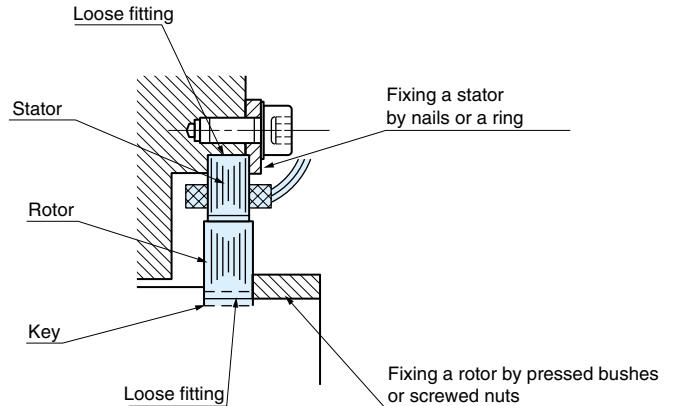
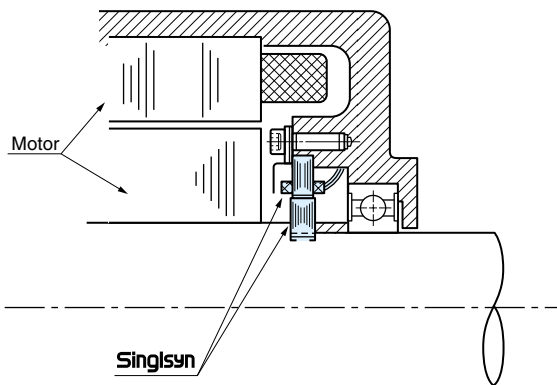
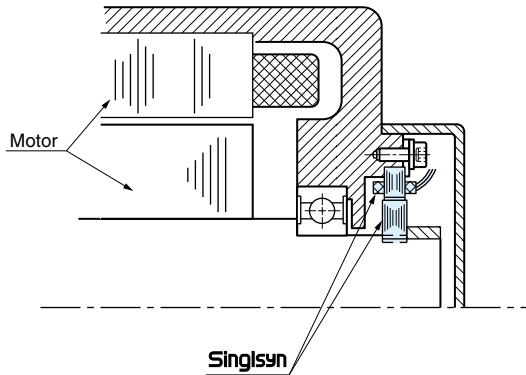

Detail Drawing for mounting **Singlsyn**

- An electrical error caused by a stator eccentricity error of 0.05 mm

Function		2X-BRX	3X-BRX	4X-BRX
Size	S10	45'	10'	5'
	S15	35'	3'	2'
	S21	10'	2'	1'

- An electrical error caused by a Rotor eccentricity error of 0.05 mm

Function		2X-BRX	3X-BRX	4X-BRX
Size	S10	30'	3'	3'
	S15	10'	2'	1'
	S21	3'	1'	1'

● Mounting Accuracy

In case **Singlsyn** is mounted in rough accuracy, the performance of **Singlsyn** may not be fully performed.

The eccentricity between a rotor and a stator affects its electrical accuracy as shown in the right table.

● Allowable Axial Deflection

The deflection in the axial direction between a stator and a rotor should be within ± 0.25 mm.

Cautions for use

- The excitation input voltage in the specification sheet is described as a rated value. It is no problem for **Singlsyn** to be used in a range from 3 V to 1.2 times of the rated voltage, but the frequency should be $\pm 5\%$ of the rated value. Or else its accuracy may be degraded.
- In case of presence of large noise source in the vicinity or in case of a long transmission line, basically twisted pair lines with shield in each pair should be used. Additionally a different amplifier should be used as a receiver if any noise is induced in output signals.
- If **Singlsyn** is mounted without eccentricity nor a tilt and a run-out for the shaft of a measuring object, some significant electrical errors may occur in output signals of the **Singlsyn**. Therefore users should take care of mounting **Singlsyn** mechanically as described in the above mounting method.
- If **Singlsyn** is connected to imbalanced loads for each output of 2-phases, two output voltages become imbalanced and may result in some electric errors. Therefore the loads of 2-phases should be in the same condition.
- In case of the presence of a strong external magnetic field around **Singlsyn**, it affects the magnetic flux in the **Singlsyn** and may result in some electrical errors. In this case please consider setting some shielding in the **Singlsyn**.
- If **Singlsyn** is used in the conditions of relative humidity of near 100% for a long time, the electrical insulation of the **Singlsyn** may gradually get worse. In such a case some protective cover for the **Singlsyn** is recommended.



TAMAGAWA TRADING CO.,LTD
A COMPANY OF TAMAGAWA SEIKI CO.,LTD

HEAD OFFICE :

1879 OHYASUMI, IIDA, NAGANO PREF, 395-8515, JAPAN

PHONE : 0265-21-1840

FAX : 0265-21-1864

TOKYO OFFICE :

3-19-9 SHINKAMATA, OHTA-KU, TOKYO 144-0054, JAPAN

PHONE : 03-3738-3132

FAX : 03-3738-3175



JAB
QS,QMS
Accreditation
R014,RE012



WARRANTY

Tamagawa Seiki warrants that this product is free from defects in material or workmanship under normal use and service for a period of one year from the date of shipment from its factory. This warranty, however, excludes incidental and consequential damages caused by careless use of the product by the user. Even after the warranty period, Tamagawa Seiki offers repair service, with charge, in order to maintain the quality of the product. The MTBF (mean time between failures) of our product is quite long; yet, the predictable failure rate is not zero. The user is advised, therefore, that multiple safety means be incorporated in your system or product so as to prevent any consequential troubles resulting from the failure of our product.

All specifications are subject to change without notice.

ISO 14001 Certificate on Head office

URL <http://www.tamagawa-seiki.co.jp>

'01.5

T12-1579N1. 3,000. 2001.5